

## Specifications

### GC-760 XL PRO Case Maker

#### Case Making Capability:

Maximum Case Size (Open)	760 x 1,070mm
Minimum Case Size (Open)	145 x 145mm
Cover Material Thickness	80-250Gsm
Spine Thickness	1-100mm
Board Thickness	1.5-4mm
Minimum Gap Between Boards (No Spine Cover)	4mm
Turning of Paper Edge	10-20mm
Maximum Print Size	1,110 x 800mm

#### Productivity:

Production Speed	2 - 3 Cases Per Minute
Glue Roller Speed	5.6 to 16 Metres Per Minute

#### Operational Components:

Glue Tank Heater	Water Filled Immersion Heater
Operating Temperature	0-95 Degrees Celsius
Temperature Controller	Digital Touch Screen
Glue Tank Capacity	5 Litres
Heating Time	20-25 Minutes
Table Vacuum	Integrated High Power Vacuum
Glue Application Method	Stainless Steel Rollers
Clean Down Time After Use	2 Minutes Max

#### Standard Features:

- User Friendly, Intuitive Touch Screen Controls (Delta PLC)
- All Functions of Heat, Speed & Operation Method done via Touch Screen
- Auto Edge Turning on Two Sides Simultaneously with Return to Operator
- Option to Deliver Cases back to the Operator or to Rear Delivery Table
- Ironing Function for Pressing of Finished Cases (Removes Air Pockets)
- Solid Core, Stainless Steel Acid Resistant Glue Application Rollers
- Glue Tank Housed within Case Table for Ergonomic Operation
- Water Filled Immersion Heater - Gives Precise Heat of the Glue
- Pre-Heat Bar - Removes any Condensation on the Cover Material
- Light Bar in the Centre of the Table for Easy Spine Text Alignment
- Optional Rigid Board Kit Allows Application of Glue on to Boards up to 5mm
- Powerful Vacuum Table on Full Area of the Case Maker
- Anodised Steel Cover Guides with Special Non-Adhesive Coating
- Magnetic Stops with Pin Hole Positioning Across full area of Case Maker
- Combined Weight Bar & Brushes to Reliably Perform Edge Turning

**Power Supply:** 400V AC - 16 Amp 5 Pin Commando Plug

**Current Consumption:** 3.8 KW Under Full Load

**Net Weight:** 650Kgs

AfterPrint Ltd  
Unit F, Hoyle Point  
Hoyle Street  
Warrington  
Cheshire  
WA5 0LW

Tel +44(0) 01925 611560  
Hello@AfterPrintLtd.co.uk  
www.AfterPrintLtd.co.uk

AP is a trade mark of AfterPrint Ltd. AfterPrint has a policy of continuous improvement & reserves the right to amend any specifications listed within this document without prior notice.

Specifications are based on optimal operating conditions and may vary depending on stock & environmental conditions. As part of our continuous improvement program, specifications are subject to change without prior warning or notice.

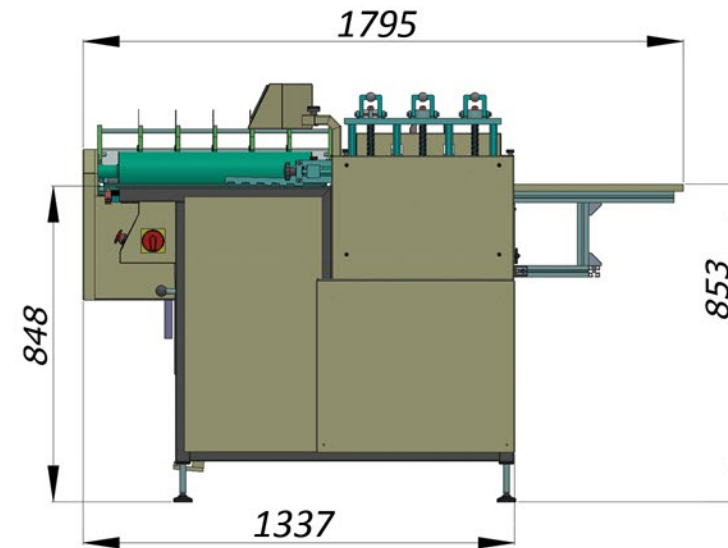

Above: GC-760 XL PRO Dimensions (Side View)

Below: GC-760 XL PRO Dimensions (Front Operator View)

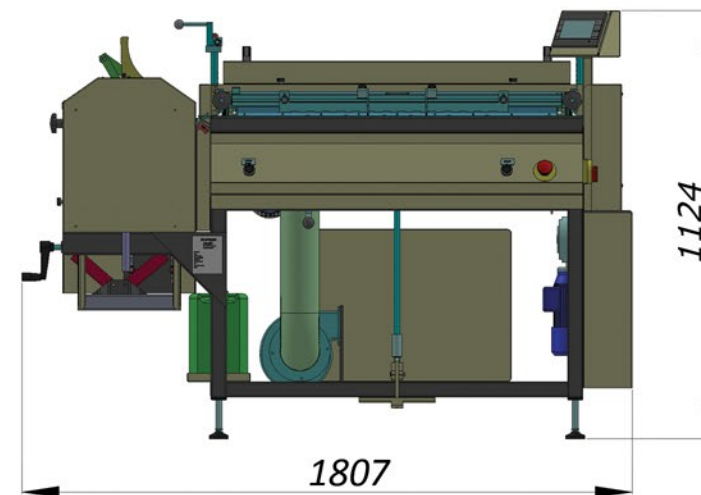

Note: Minimum Door Width is 1380mm with option of disassembly to fit through access door of 1,000mm (Vertical Transport)



# GC-760 XL Pro Case Maker

Professional Semi-Automated Large Format Case Making Solution

Hot or Cold Glue Application  
Water Heated Glue Tank  
Vacuum Table on Case Maker  
Automated Edge Turning

Semi-Automated Case Making Solution equipped with Automated Edge Turning & Professional Gluing unit capable of operation with both hot & cold glue types. Easily produce high quality cases and covers in any format and thickness. Ideal for the production of Luxury Books, Photo Albums, Ring Binders, Clip Boards, Luxury Rigid Boxes, Duplex Business Cards, & Restaurant Menu's.



GRAFACUT is a brand of Print Finishing machines proudly manufactured in Poland. Grafacut have over 40 Years of experience as designers and manufacturers of Print Finishing machines and specialise in Guillotines, Label Punches, UV Coaters and Case Making Machinery. Their products are almost fully produced inside of their premises with all processes such as grinding, milling, turning and powder coating done on site which ensures the quality of their products from the very beginning.

Grafacut build compact, sturdy machinery which have a robust design to serve their owners for many years. Built on their partnerships with their distributors around the world and by listening to the feedback from customers; The Grafacut range of Case Makers & Gluing Machines have become synonymous with reliability and exceptional build quality.

### Why Choose the GC-760 XL Pro?

The Grafacut GC-760 XL Pro is a semi-automatic case making machine with automated 2 edge turning in module. It allows the production of wide format hard covers, photo albums or parts for rigid boxes. The Pro consists of a professional hot & cold gluing machine with large diameter full stainless steel rollers, vacuum table with backlight, positioning device for multi-piece cases & an auto turning in mechanism with pressing rollers. It is designed as a Professional Machine for small to medium run lengths in formats from 145 x 145 to 760 x 1,070mm. The larger format that the 760 XL Pro offers with its 800mm wide gluing rollers makes it popular choice for customers looking to glue & spot rigid boxes whilst also being able to offer high quality wide format cases.



### User Friendly Operation

One of the key attributes to all the Grafacut Machinery is the thought and effort that goes into making their machines intuitive to use and friendly to any operator. The GC-760 XL Pro Case Maker is no exception with the incorporation of a full colour touchscreen controller. The screen pivots 180 degrees so it can be utilised from the front or rear of the machine, always keeping the controls at your fingertips. The touch screen provides instant access to the glue temperature settings, edge turning requirement, gluing roller activation, gluing roller speed and backlight controls. The screen also provides system diagnostics, language settings & roller cleaning mode activation as well as the all important service modes.



All the Control Right at your Finger Tips  
Intuitive Colour Touch Screen Controller  
Comes as Standard on the GC-480 Pro

### Simple, Fast & Accurate

The ergonomic design of the GC-760 XL Pro ensures the case making process is intuitive, simple to perform and easy enough for any operator to feel at ease with the machine within seconds. An integrated professional gluing machine applies a thin layer of glue to the outer cover which is rotated and given back to the operator ready to lay down on the vacuum table. The cover is secured in place by the vacuum whilst the operator places the spine and board covers using the steel guides and sidelay. Once assembled the operator simply pushes the open case into the edge turning mechanism, 2 edges are folded & the case is returned back to the front table. The operator rotates the case and pushes it back into the edge turning unit, the remaining 2 edges are folded and the case is complete.

### A Complete Case Making Solution

The Grafacut GC-760 Pro XL is a complete case making workstation. Incorporating a professional gluing machine offering both Hot & Cold gluing applications, vacuum table, foot treadle operated back guides & backlight as well as an automated 2 edge turning in device with 6 fully adjustable press rollers for perfect results.

The large table over the edge turning unit provides an excellent storage area for covers & boards keeping them within easy reach whilst also streamlining your workflow. The GC-760 XL Pro is capable of producing between 120-150 cases per hour!

### An Overview of the Grafacut GC-760 Pro XL Features

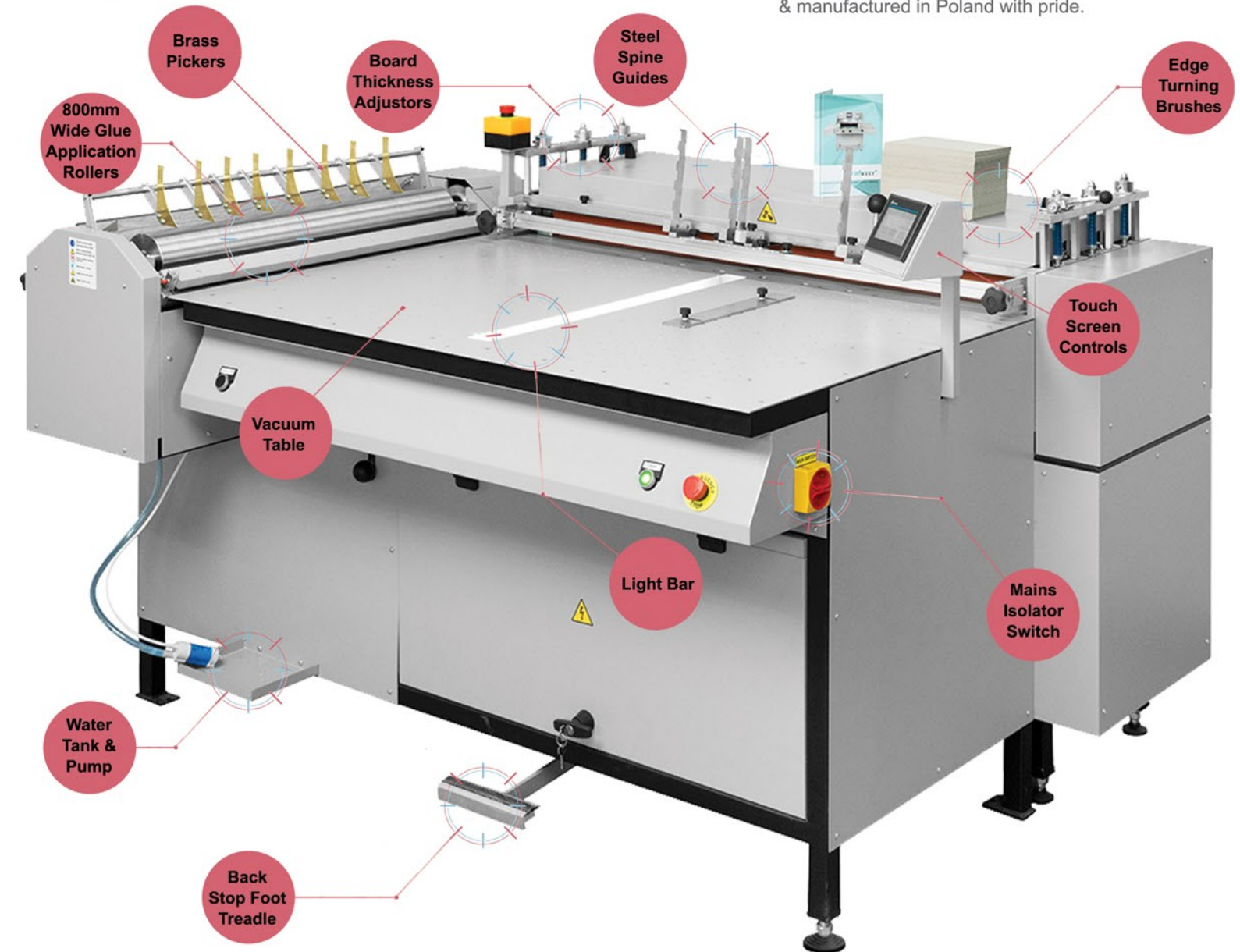

### Objective Achieved

Grafacut started this development journey with one goal in mind - to create a device which fills the niche between more automated solutions & cheap devices of low quality and low flexibility in terms of materials. The end result is the creation of the Grafacut GC series of Case Makers which bring a new level of flexibility and professionalism to the case making arena. Grafacut recently expanded the range which now includes 5 different models offering cases ranging from 30 x 70 to 770 x 1,070mm. The entire GC series of case makers are 100% designed & manufactured in Poland with pride.



Extremely Robust Construction, All Steel Design  
with World Leading Electronics for Ultimate Reliability



Optional Rigid Board Kit Locks into Place and Allows Materials  
upto 5mm in Thicknes to be Processed Through the Gluing Rollers

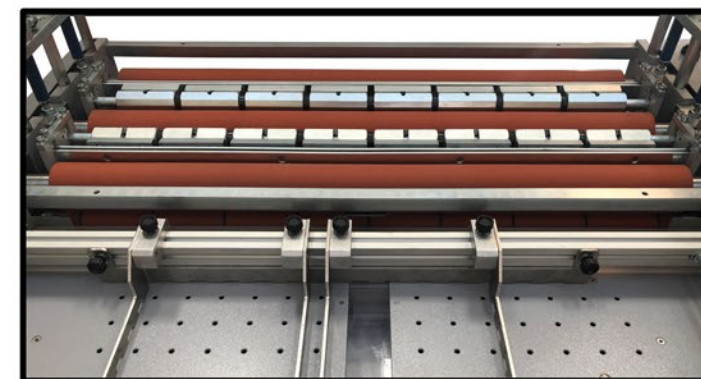

Silicone Rubber Pressure Rollers Combined with Weighted  
Edge Turning Brushes Provide Excellent Results

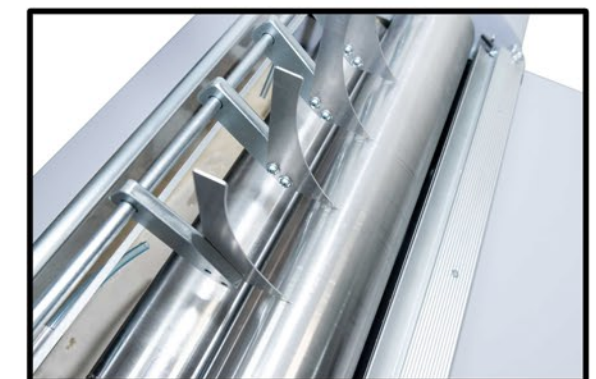

Solid Steel Acid Resistant Rollers with Brass  
Pickers, Curved to Return the Media to the Operator